

S.50-921

Ideal choice for very heavy transportation.
Assembling belt for cars and truck loading systems.
FDA approved.

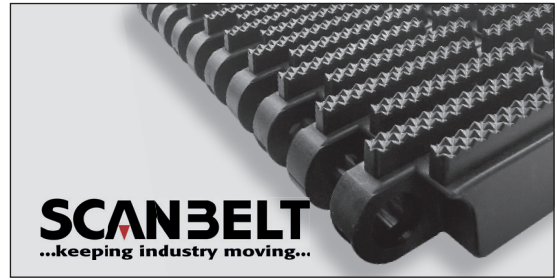

SCANBELT
...keeping industry moving...

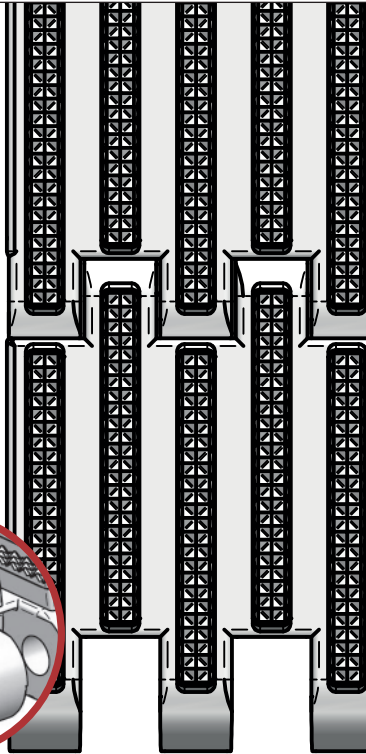

SUGGESTED INDUSTRIES



STANDARD FEATURES

Belt surface	Raised rib 5 mm, 1,25 mm non-skid
Open area	Closed
Strength	Ideal choice for very heavy-duty transportation
Cleanability	Good
Standard width	Increments of 20 mm, e.g. 100, 120 mm etc.

BELT DATA

Belt materials	Temperature range		Max. belt pull kg/m of width	Belt weight kg/m ²	Belt weight kg/m ² w. steel rods	Standard Colours
	Min.	Max.				
PE	- 73	66	4800	16	22	Black
PP	+ 5	100	6000	16	22	Black
POM	- 43	95	10250	24	30	Black

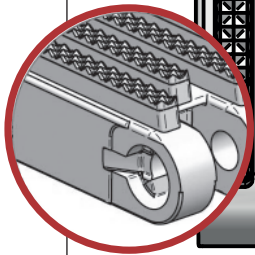

PROTECTED BY THE EU DESIGN REGISTRATION

ACCESSORIES

Type	mm
Flights	25
Scoop Flights	-
Bent Flights	-
Supported Flights	-
Comb Flights	25, 50, 60
Flights fitted with a Round Top	-
Moulded Side Guards	-
Friction Top	-
Hold-downs	-

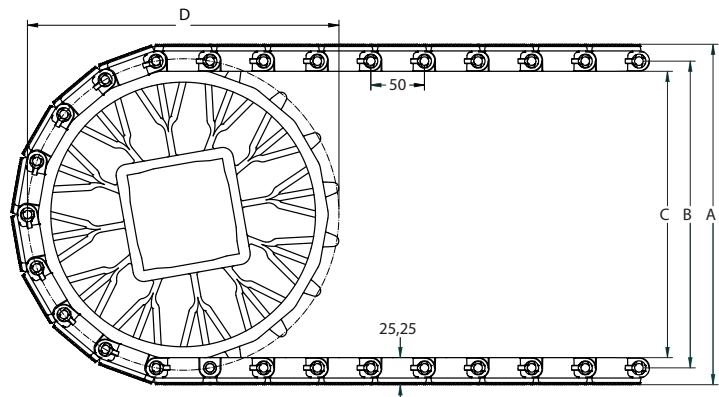

SPROCKET DATA

A = Outside, B = Pitch, C = Inside, D = Pitch Circle Diameter

No. Teeth	A	B	C	D	Hub Width	Round Bore		Square Bore	
	mm	mm	mm	mm		mm	Inch	mm	Inch
12	217	188	169	195	40	40 / 60		60 / 80 / 90	
16	283	254	235	259	40	40 / 60		60 / 80 / 90	
18	317	288	269	291	40	40 / 60		60 / 80 / 90	